

## Description



These switches are used on machines where the hazardous conditions remain for a while, even after the machines have been switched off, for example because of mechanical inertia of pulleys, saw disks, parts under pressure or with high temperatures. Thus, the switches can also be used if individual guards are only to be opened under certain conditions.



Versions with mode 1 (safety outputs active when guard closed and locked) are interlocks with guard locking acc. to ISO 14119; the product is labelled with the symbol shown.

## Maximum safety with a single device

**PL e + SIL 3** The NG series switches are constructed with redundant electronics. As a result, the maximum PL e and SIL 3 safety levels can still be achieved through the use of a single device on a guard. This avoids expensive wiring in the field and allows faster installation. Inside the control cabinet, the two electronic safety outputs must be connected to a safety module with OSSD inputs or to a safety PLC.

## Series connection of several switches

**PL e + SIL 3** One of the most important features of the NG series is the possibility of connecting up to 32 sensors in series, while still maintaining the maximum safety levels PL e laid down in EN 13849-1 and SIL 3 acc. to EN 62061.

This connection type is permissible in safety systems which have a safety module at the end of the chain that monitors the outputs of the last NG switch. The fact that the PL e safety level can be maintained even with 32 sensors connected in series demonstrates the extremely secure structure of each single device.

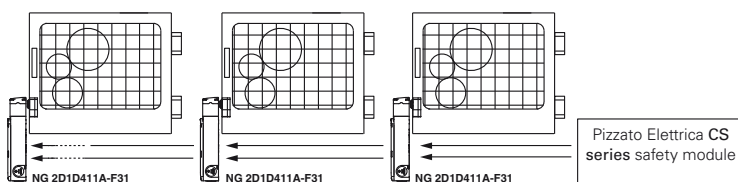

## Series connection with other devices

**PL e + SIL 3** The NG series features two safety inputs and two safety outputs, which can be connected in series with other Pizzato Elettrica safety devices. This option allows the creation of safety chains containing various devices. For example, stainless steel safety hinges (HX BEE1 series), transponder sensors (ST series) and door lock sensors (NG series) can be connected in series while still maintaining the maximum PL e and SIL 3 safety levels.

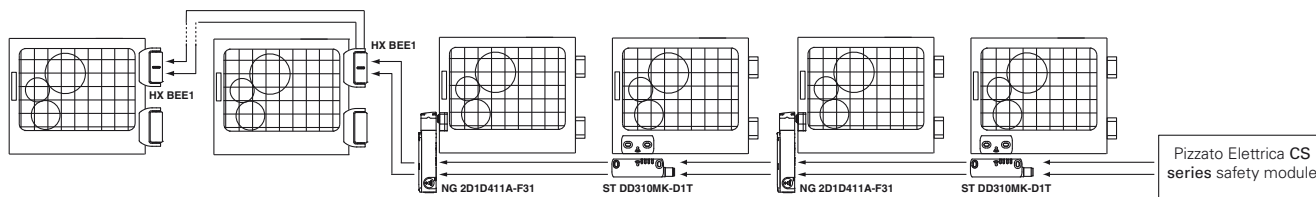

## RFID actuators with high coding level



The NG series is provided with an electronic system based on RFID technology to detect the actuator. This allows to provide each actuator with different coding and makes it impossible to tamper with a device by using another actuator of the same series. Millions of different coding combinations are possible for the actuators. They are therefore classified as high level coded actuators, according to EN ISO 14119.

## Holding force of the locked actuator

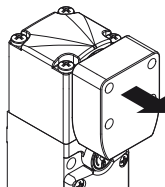

**9750 N** The strong interlocking system guarantees a maximum actuator holding force of  $F_{1max} = 9750 \text{ N}$ . This is one of the highest values currently available on the market today, making this device suitable for heavy-duty applications.

## Dustproof

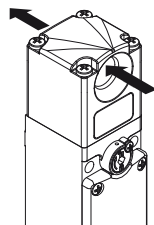

The switch is provided with a through hole for inserting the actuator. Thanks to this unique feature, any dust that enters the actuator hole can always come out on the opposite side instead of remaining inside. Moreover, the lock pin is provided with a diaphragm seal, making the system suitable for critical environments with a high level of dust.

## Integrated control devices

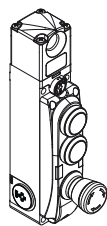

The switch is also available with elevated cover. Control devices such as buttons, emergency buttons, indicator lights or selectors can thereby be attached directly to the switch together with corresponding contact blocks.

The result is a compact solution with direct access to control devices without needing to install them separately on the switch panel or in their own housing. The devices can be illuminated and, thanks to the PUSH-IN spring-operated connections, wiring is quick and intuitive.

## Centring

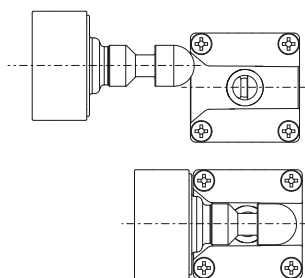

The switch is provided with a wide centring inlet for the actuator pin. This solution makes it easier to align the actuator and the opening hole on the head during installation. Moreover, this solution drastically reduces the probability of a collision between the switch and the actuator, making it possible to install the device even on inaccurately closing doors.

## Push-in spring-operated connections



The switch is provided with a PUSH-IN type spring-operated connection system on the inside. This technology allows wiring to be performed quickly and easily, as the wire just needs to be inserted into the appropriate hole in order to establish the electrical connection and automatically secure the wire. This operation can be performed with rigid or flexible wires with a crimped wire-end sleeve and requires no tools. Release is obtained by pressing the appropriate wire-releasing button.



### Six LEDs for immediate diagnosis



As the LEDs have been designed for quick immediate diagnosis, the status of each input and output is highlighted by one specific LED. This makes it possible to quickly identify the interruption points in the safety chain, which device is released, which door is opened and any errors inside the device. All of this at a glance, without needing to decode complex flashing sequences.

### Holding force of the unlocked actuator

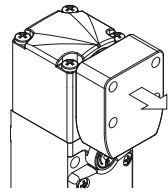

The inside of each switch features a device which holds the actuator in its closed position. Ideal for all those applications where several doors are unlocked simultaneously, but only one is actually opened. The device keeps all the unlocked doors in their position with a retaining force of 30 N~, stopping any vibrations or gusts of wind from opening them.

### Protection against tampering

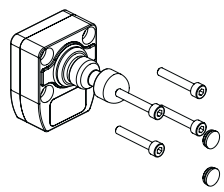

Each actuator of the NG series is supplied with four protective caps. Not only do the caps prevent dirt from accumulating and simplify cleaning, they also block access to the fastening screws of the actuator. As a result, standard screws can be used instead of tamper-proof screws.

### Articulated actuator for inaccurately closing doors

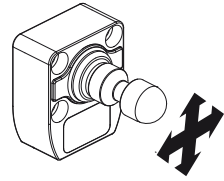

needing to be angled.

All NG series actuators are articulated, thereby allowing the actuator pin to be safely guided into the switch through the centring hole. As a result, the actuator and switch do not need to be precisely aligned during installation. In addition, the device can thereby be used on doors with a minimum actuation radius of 150 mm without the actuation pin

### Function for protecting against recoil forces

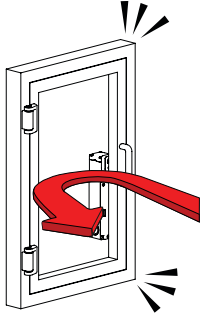

If a door is closed too quickly or with so much force that the recoil would cause it to open again, a special function in the NG switch prevents locking. This function prevents the immediate locking of the door if the lock signal is applied. This protects the switch against recoil forces that occur during instantaneous locking. This serves to protect the switch from damage and forces the operator to close the door more gently.

### Head and devices with variable orientation

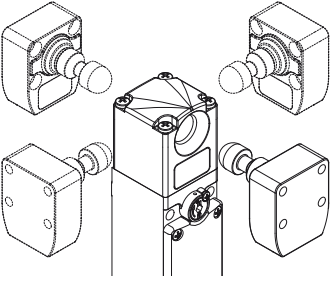

The system can be variably configured by loosening the 4 screws on the head. The key release device and the emergency release button can also be rotated and secured independently of one another in steps of 90°. The device can thus assume 16 different configurations.

### Key release device and emergency release button

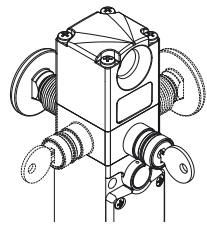

The key release device (auxiliary release) is used to permit unlocking of the actuator only by personnel in possession of the key. The device also functions with no power supply and, once actuated, prevents the guard from being locked. The emergency release button (escape release) allows actuator release and immediate opening of the door. Generally

used in machines within which an operator could inadvertently become trapped, it faces towards the machine interior, to allow the operator to exit even in the event of a power failure. The button has two stable states and can be freely extended in length with suitable extensions (see accessories). Both devices can be positioned on the four sides of the switch. As a result, it can be installed both towards the interior and towards the exterior of the machine.

### Non-detachable head and release devices

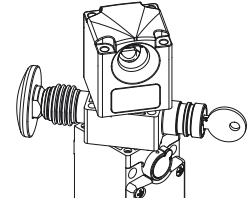

The head and the release device can be rotated but cannot be detached from each other. This makes the switch more secure since the problem of incorrect assembly by the installer cannot occur; in addition, the risk of damage is lower (loss of small parts, penetration of dirt, etc.).

### High protection degree

**IP69K**  
**IP67**

These devices are designed to be used in the toughest environmental conditions and they pass the IP67 immersion test acc. to EN 60529. They can therefore be used in all environments where maximum protection degree of the housing is required. Due to their special design, these devices are suitable for use in equipment subjected to cleaning with high pressure hot water jets. These devices meet the IP69K test requirements according to ISO 20653 (water jets with 100 bar and 80°C).

### Two safety output actuation modes

**CLOSED**  
**OR**  
**CLOSED & LOCK**

Two different activation modes are available for the switch: active safety outputs with guard closed and locked (mode 1) for machines with inertia or active safety outputs with guard closed (mode 2) for machines without inertia.

### External device monitoring

**EDM**

On request, the switch can be supplied with EDM function (External Device Monitoring). In this case, the switch itself checks the proper function of the devices connected to the safety outputs. These devices (usually relays or safety contactors) must send a feedback signal to the EDM input, which checks that the received signal is consistent with the state of the safety outputs.

Selection diagram

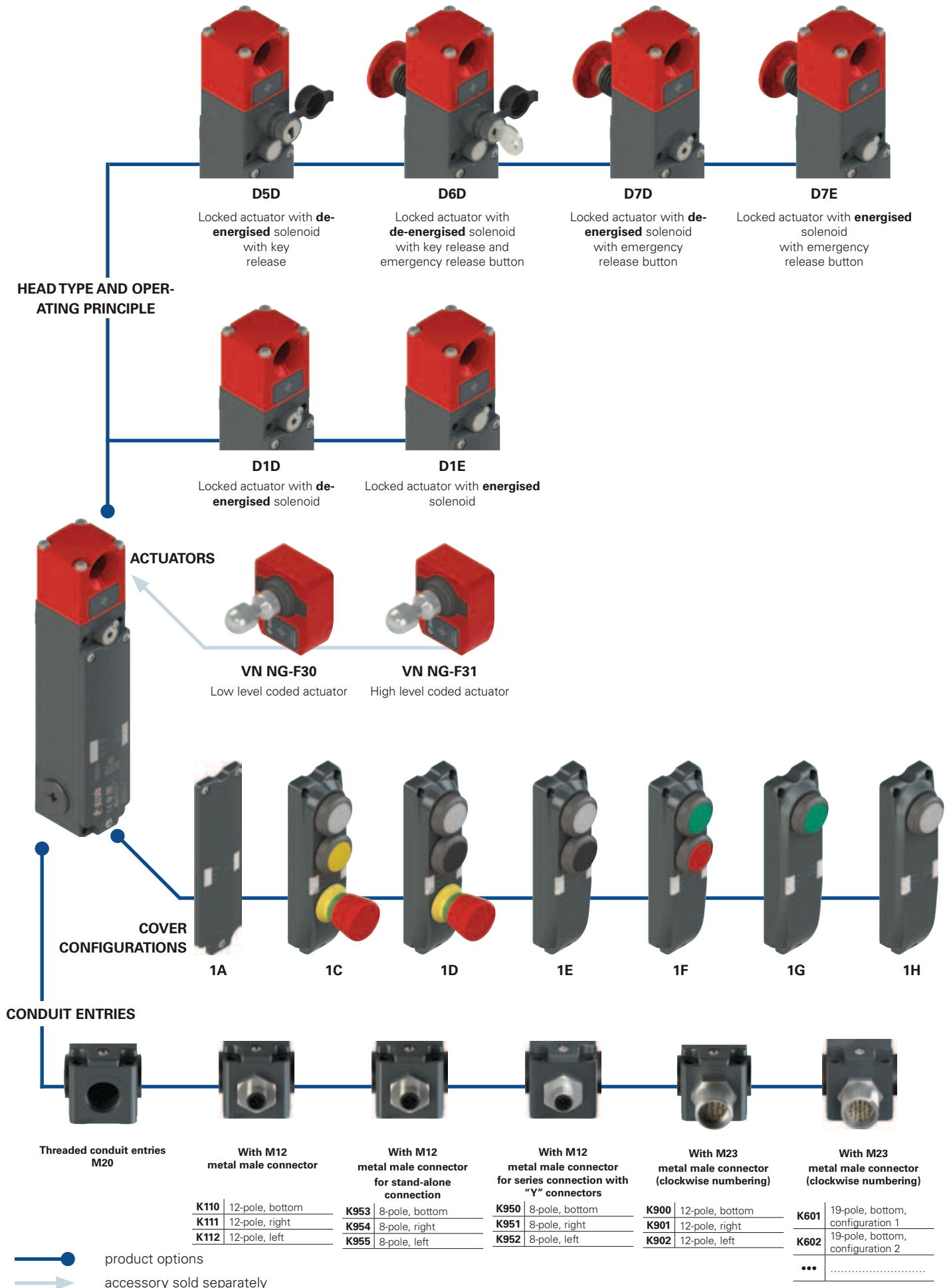

**Code structure****Attention!** The feasibility of a code number does not mean the effective availability of a product. Please contact our sales office.

article
options

**NG 2D1D411A-F31E34K900LP30**

**Operating principle**

<b>D1D</b>	locked actuator with de-energised solenoid
<b>D1E</b>	locked actuator with energised solenoid
<b>D5D</b>	locked actuator with de-energised solenoid. With key release
<b>D6D</b>	locked actuator with de-energised solenoid. With key release and emergency release button
<b>D7D</b>	locked actuator with de-energised solenoid. With emergency release button
<b>D7E</b>	locked actuator with energised solenoid. With emergency release button

**Release button length**

	for max. 15 mm wall thickness (standard)
<b>LP30</b>	for max. 30 mm wall thickness
<b>LP40</b>	for max. 40 mm wall thickness
<b>LP50</b>	for max. 50 mm wall thickness
<b>LP60</b>	for max. 60 mm wall thickness
...	other wall thicknesses on request

**Inputs and outputs**

<b>3</b>	2 safety inputs IS1, IS2 2 safety outputs OS1, OS2 1 signalling output O3: closed guard 1 signalling output O4: locked guard 1 solenoid activation input I4 <small>Note: Supplied only together with actuator</small>
<b>4</b>	2 safety inputs IS1, IS2 2 safety outputs OS1, OS2 1 signalling output O3: closed guard 1 signalling output O4: locked guard 1 solenoid activation input I4 1 programming input I3
<b>5</b>	2 safety inputs IS1, IS2 2 safety outputs OS1, OS2 1 signalling output O3: closed guard 1 signalling output O4: locked guard 1 solenoid activation input I4 1 programming input I3 1 feedback input EDM I5
<b>6</b>	2 safety inputs IS1, IS2 2 safety outputs OS1, OS2 1 signalling output O3: closed guard 1 signalling output FAULT O4 1 solenoid activation input I4 1 programming input I3

**Activation of OS outputs**

<b>1</b>	mode 1: OS safety outputs active with locked guard
<b>2</b>	mode 2: OS safety outputs active with closed guard

**Pre-installed connectors**

	without connector (standard)
<b>K110</b>	M12 metal connector, 12-pole, bottom
<b>K601</b>	M23 metal connector, 19-pole, bottom, configuration 1
<b>K900</b>	M23 metal connector, 12-pole, bottom
<b>K950</b>	M12 metal connector, 8-pole, bottom, for series connection
<b>K953</b>	M12 metal connector, 8-pole, bottom, for stand-alone connection
...	other connectors on request

For the complete list of possible combinations please contact our technical department.

**Actuator extraction force**

	actuator extraction force 30 N (standard)
<b>E34</b>	actuator freely removable

**Actuator**

<b>F30</b>	low level coded actuator VN NG-F30 the switch recognises any type F30 actuator
<b>F31</b>	high level coded actuator VN NG-F31 the switch recognises one single type F31 actuator

**Cover configurations**

<b>1A</b>	standard cover
<b>1C</b>	cover with white button / yellow button / emergency button with rotary release
<b>1D</b>	cover with white button / black button / emergency button with rotary release
<b>1E</b>	cover with white button / black button
<b>1F</b>	cover with green button / red button
<b>1G</b>	cover with green button
<b>1H</b>	cover with white button
...	other configurations on request

**Code structure for actuator****VN NG-F30****Actuator**

<b>F30</b>	low level coded actuator the switch recognises any type F30 actuator
<b>F31</b>	high level coded actuator the switch recognises one single type F31 actuator



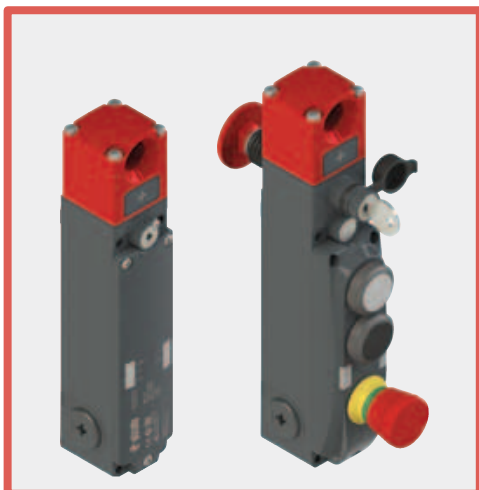

### Main features

- Actuation without contact, using RFID technology
- Digitally coded actuator
- Actuator holding force: 9750 N
- SIL 3 and PL e with a single device
- Optional integrated control devices
- Metal housing, three M20 conduit entries
- Protection degree up to IP67 and IP69K
- Versions with key release and emergency release button
- PL e also with series connection of up to 32 devices
- Signalling LED

### Quality marks:



UL approval: E131787  
 TÜV SÜD approval: Z10 15 01 75157 005  
 EAC approval: RU C-IT.AД35.B.00454

### In compliance with standards:

EN ISO 14119, EN 60947-5-3, EN 60947-1, IEC 60204-1, EN 60204-1, EN ISO 12100, IEC 60529, EN 60529, EN 61000-6-2, EN 61000-6-3, BG-GS-ET-19, IEC 61508-1, IEC 61508-2, IEC 61508-3, IEC 61508-4, SN 29500, EN ISO 13849-1, EN ISO 13849-2, EN 62061, EN 61326-1, EN 61326-3-1, EN 61326-3-2, ETSI 301 489-1, ETSI 301 489-3, ETSI 300 330-2, UL 508, CSA 22.2 No.14

### Compliance with the requirements of:

Machinery Directive 2006/42/EC  
 EMC Directive 2014/30/EU  
 Directive 2014/53/EU - RED  
 FCC Part 15

### Connection terminals

Connection system: PUSH-IN spring type  
 Cross-section of rigid/flexible wires w. wire-end sleeve: min. 1 x 0.34 mm<sup>2</sup> (1 x AWG 22)  
 max. 1 x 1.5 mm<sup>2</sup> (1 x AWG 16)  
 Wire cross-section with pre-insulated wire-end sleeve: min. 1 x 0.34 mm<sup>2</sup> (1 x AWG 22)  
 max. 1 x 0.75 mm<sup>2</sup> (1 x AWG 18)  
 Cable stripping length (x):   
 min.: 8 mm  
 max.: 12 mm

## Technical data

### Housing

Metal head and housing, baked powder coating.  
 Three threaded conduit entries: M20x1.5  
 Protection degree: IP67 acc. to EN 60529  
 IP69K acc. to ISO 20653  
 Protection degree with control devices: IP65 acc. to EN 60529 with cable gland of equal or higher protection degree

### General data

SIL level (SIL CL): up to SIL 3 acc. to EN 62061  
 Performance Level (PL): up to PL e acc. to EN ISO 13849-1  
 Safety category: up to cat. 4 acc. to EN ISO 13849-1  
 Interlock with lock, no contact, coded: type 4 acc. to EN ISO 14119  
 Level of coding acc. to EN ISO 14119: low with F30 actuator  
 High with F31 actuator  
 Safety parameters:  
 MTTF<sub>D</sub>: 1883 years  
 PFH<sub>D</sub>: 8.07 E-10  
 DC: High  
 Service life: 20 years  
 Ambient temperature: -20°C ... +50°C  
 Max. actuation frequency  
 with actuator lock and release: 600 operating cycles/hour  
 Mechanical endurance: 1 million operating cycles  
 Max. actuation speed: 0.5 m/s  
 Min. actuation speed: 1 mm/s  
 Maximum force before breakage F<sub>1max</sub>: 9750 N acc. to EN ISO 14119  
 Max. holding force F<sub>Zh</sub>: 7500 N acc. to EN ISO 14119  
 Maximum clearance of locked actuator: 4 mm  
 Released actuator extraction force: 30 N  
 Tightening torques for installation: see page see page 313-324

### Electrical data of IS1/IS2/I3/I4/I5/EDM inputs

Rated operating voltage U<sub>e1</sub>: 24 Vdc  
 Rated current consumption I<sub>e1</sub>: 5 mA

### Electrical data of OS1/OS2 safety outputs

Rated operating voltage U<sub>e2</sub>: 24 Vdc  
 Output type: PNP type OSSD  
 Maximum current per output I<sub>e2</sub>: 0.25 A  
 Minimum current per output I<sub>m2</sub>: 0.5 mA  
 Thermal current I<sub>th2</sub>: 0.25 A  
 Utilization category: DC13; U<sub>e2</sub>=24 Vdc, I<sub>e2</sub>=0.25 A  
 Short circuit detection: Yes  
 Overcurrent protection: Yes  
 Internal self-resettable protection fuse: 1.1 A  
 Duration of the deactivation impulses at the safety outputs: < 300 µs  
 Permissible maximum capacitance between outputs: < 200 nF  
 Permissible maximum capacitance between output and ground: < 200 nF  
 Response time upon deactivation of IS1/IS2 inputs:

Response time upon actuator removal: typically 7 ms, max. 15 ms  
 typically 120 ms, max. 200 ms

### Electrical data of O3/O4 signalling output

Rated operating voltage U<sub>e3</sub>: 24 Vdc  
 Output type: PNP  
 Maximum current per output I<sub>e3</sub>: 0.1 A  
 Utilization category: DC12; U<sub>e3</sub>=24 Vdc, I<sub>e3</sub>=0.1 A  
 Short circuit detection: No  
 Overcurrent protection: Yes  
 Internal self-resettable protection fuse: 1.1 A

### RFID sensor data

Assured operating distance S<sub>ao</sub>: 2 mm  
 Assured release distance S<sub>ar</sub>: 4 mm (actuator not locked)  
 10 mm (actuator locked)  
 Rated operating distance S<sub>n</sub>: 2.5 mm  
 Repeat accuracy: ≤ 10 % s<sub>n</sub>  
 Differential travel: ≤ 20 % s<sub>n</sub>  
 Max. switching frequency: 1 Hz

### Power supply electrical data:

Rated operating voltage U<sub>e</sub> SELV: 24 Vdc ±10%  
 Operating current at U<sub>e</sub> voltage:  
 - minimum: 40 mA  
 - with activated solenoid: 0.4 A  
 - with activated solenoid and all outputs at maximum power: 1.2 A  
 Rated insulation voltage U<sub>i</sub>: 32 Vdc  
 Rated impulse withstand voltage U<sub>imp</sub>: 1.5 kV  
 External protection fuse: 1.5 A / 1.6 A type F or equivalent device  
 III  
 Overvoltage category: III  
 Electrical endurance: 1 million operating cycles  
 Solenoid duty cycle: 100% ED (continuous operation)  
 Solenoid consumption: 9 W max.



### Features approved by UL

Utilization categories: 24 Vdc, 0.25 A (resistive load).

Inputs supplied by remote class 2 source or limited voltage and limited energy

In compliance with standard: UL 508, CSA 22.2 No.14

Please contact our technical department for the list of approved products.

### Features approved by TÜV SÜD

Protection degree: IP67, IP69K  
 Ambient temperature: -20°C...+50°C  
 Storage temperature: -40°C...+75°C  
 PL, category: PL e, cat. 4  
 SIL: SIL 3 / SIL CL 3

In compliance with standards: 2006/42/EC, EN 60947-1/A1:2011, EN 60947-5-2/A1:2012, EN 60947-5-3:2013, EN ISO 14119:2013, EN 61508-1:2010 (SIL 3), EN 61508-2:2010 (SIL 3), EN 61508-3:2010 (SIL 3), EN 61508-4:2010 (SIL 3), EN 62061/A1:2013 (SIL CL 3), EN ISO 13489-1:2008 (PL e, cat. 4).

Please contact our technical department for the list of approved products.

### Selection table for switches with high level coded actuators

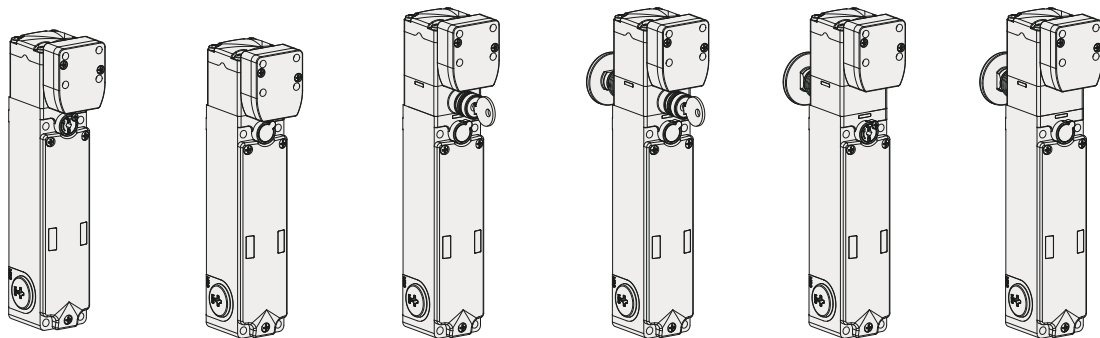

	Operating principle D, with sealable auxiliary release device	Operating principle E	Operating principle D, with key release	Operating principle D, with key release and emergency release button	Operating principle D, with emergency release button and sealable auxiliary release device	Operating principle E, with emergency release button
<b>Mode 1</b>  OS safety outputs active with locked and closed guard	NG 2D1D411A-F31	NG 2D1E411A-F31	NG 2D5D411A-F31	NG 2D6D411A-F31	NG 2D7D411A-F31	NG 2D7E411A-F31
<b>Mode 2</b> OS safety outputs active with closed guard	NG 2D1D421A-F31	NG 2D1E421A-F31	NG 2D5D421A-F31	NG 2D6D421A-F31	NG 2D7D421A-F31	NG 2D7E421A-F31

To order a product with EDM input replace number 4 with number 5 in the codes shown above. Example: NG 2D1D411A-F31 → NG 2D1D511A-F31

### Selection table for switches

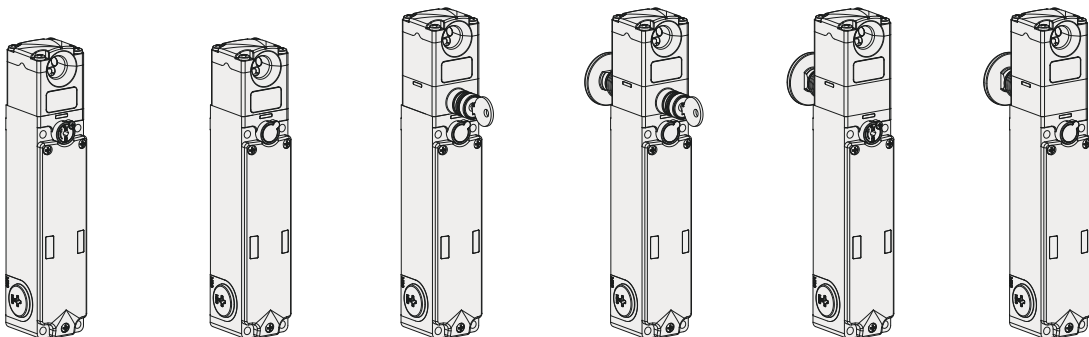

	Operating principle D, with sealable auxiliary release device	Operating principle E	Operating principle D, with key release	Operating principle D, with key release and emergency release button	Operating principle D, with emergency release button and sealable auxiliary release device	Operating principle E, with emergency release button
<b>Mode 1</b>  OS safety outputs active with locked and closed guard	NG 2D1D411A	NG 2D1E411A	NG 2D5D411A	NG 2D6D411A	NG 2D7D411A	NG 2D7E411A
<b>Mode 2</b> OS safety outputs active with closed guard	NG 2D1D421A	NG 2D1E421A	NG 2D5D421A	NG 2D6D421A	NG 2D7D421A	NG 2D7E421A

To order a product with EDM input replace number 4 with number 5 in the codes shown above. Example: NG 2D1D411A → NG 2D1D511A

Legend:  interlock with lock monitoring acc. to EN ISO 14119

### Selection table for actuators

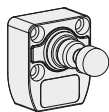

The use of RFID technology in NG series devices makes them suitable for several applications. Pizzato Elettrica offers two different versions of actuators, in order to best suit customers' specific needs.

Type F30 actuators are all encoded with the same code. This implies that a device associated with an actuator type F30 can be activated by other actuators type F30.

Type F31 actuators are always encoded with different codes. This implies that a device associated with an actuator type F31 can be activated only by a specific actuator. Another F31 type actuator will not be recognised by the device until a new association procedure is carried out (reprogramming). After reprogramming, the old actuator F31 will no longer be recognized.

Level of coding acc. to EN ISO 14119	Article
low	VN NG-F30
high	VN NG-F31

→ The 2D and 3D files are available at [www.pizzato.com](http://www.pizzato.com)

Items with code on green background are stock items

## Complete safety system

The use of complete and tested solutions guarantees the electrical compatibility between the NG series switches and the safety modules from Pizzato Elettrica, as well as high reliability. The switches have been tested with the modules listed in the adjacent table.

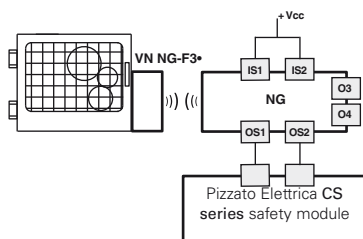

Switches	Compatible safety modules	Safety module output contacts		
		Instantaneous safety contacts	Delayed safety contacts	Signalling contacts
NG 2●●●●●●	CS AR-05●●●●●	3NO	/	1NC
	CS AR-06●●●●●	3NO	/	1NC
	CS AR-08●●●●●	2NO	/	/
	CS AT-0●●●●●●	2NO	2NO	1NC
	CS AT-1●●●●●	3NO	2NO	/
	CS MP●●●●●●		page 255	
	CS MF●●●●●●		page 283	

All NG series switches can be connected to safety modules or safety PLCs with OSSD inputs provided compatibility is ensured in advance.

NG series switches can be used as individual devices provided that the safety outputs be evaluated by a Pizzato Elettrica safety module (see table for combinable safety modules).

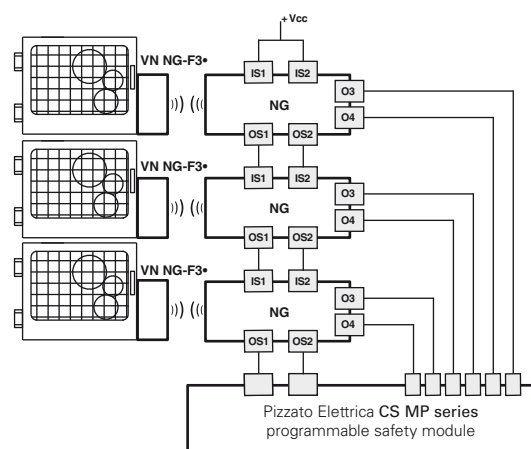
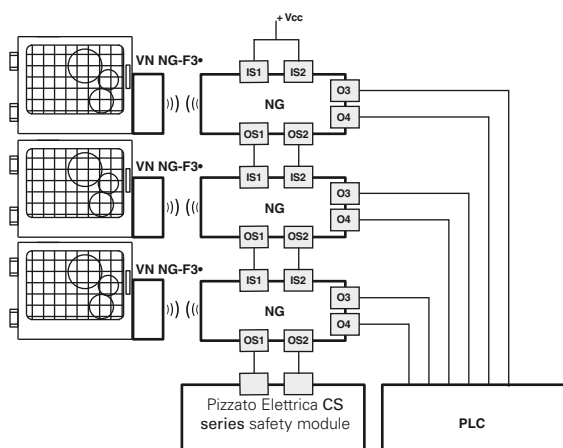

Possibility of series connection of multiple switches for simplifying the wiring of the safety system, whereby only the outputs of the last switch are evaluated by a Pizzato Elettrica safety module (see table with compatible safety modules). Each NG series switch is provided with two signalling outputs which are activated when the guard is closed (O3) or locked (O4). Depending on the specific requirements of the system that has been realised, the signals of the signalling outputs can be evaluated by a PLC.

Possibility of series connection of multiple switches for simplifying the wiring of the safety system, whereby only the outputs of the last switch are evaluated by a Pizzato Elettrica safety module of the CS MP series. Both the safety-relevant evaluation and the evaluation of the signalling outputs are performed by the CS MP series.

The examples listed above refer to applications with NG 2●●●4●●●

## Internal block diagram

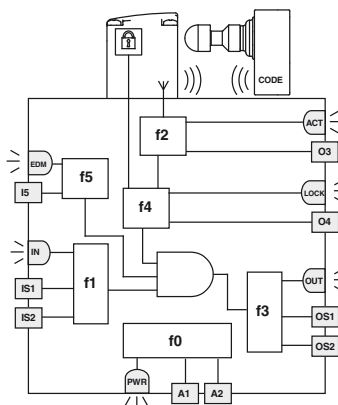

The diagram on the side represents the 6 logic functions which interact inside the device.

Function f0 is a basic function and includes the monitoring of the power supply as well as internal, cyclical tests. Function f1 monitors the status of the device inputs, whereas function f2 monitors the presence of the actuator within the detection areas of the switch. Function f4 checks the actuator lock condition.

Function f3 is intended to activate or deactivate the safety outputs and check for any faults or short circuits in the outputs.

In the EDM versions, the f5 function verifies the consistency of the EDM signal during safety output state changes. The safety-related function, which combines the sub-functions mentioned above, only activates the safety outputs for the switches in mode 1 if the input signals are correctly applied and the actuator pin is in the safe actuation area in the head and locked. The safety outputs for switches in mode 2 are activated if the input signals are correctly applied and the actuator pin is in the safe actuation area in the head. The status of each function is displayed by the corresponding LED (PWR, IN, OUT, ACT, LOCK, EDM), in such a way that the general device status becomes immediately obvious to the operator.

LED	Function
PWR	Power supply/self-diagnosis
IN	status of safety inputs
OUT	status of safety outputs
ACT	actuator state
LOCK	actuator locked
EDM	state of EDM inputs (NG 2D●●5●●●)



### Actuation sequence in mode 1

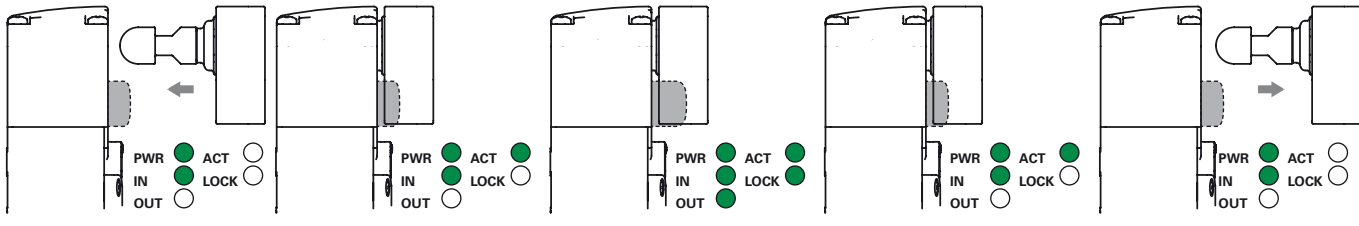

The switch is supplied with power (PWR LED on, green), the IS1 and IS2 inputs are enabled (IN LED on, green), the OS1 and OS2 safety outputs are disabled (OUT LED off). The actuator is outside of the actuation zone (LED ACT off).

When the actuator is brought inside the safe actuation area (dark grey area), the switch turns on the ACT LED (green). In this position, the O3 signalling output (door-closed) is activated. The actuator is not locked (LOCK LED off).

The I4 input can be used to lock the actuator (LOCK LED on, green). The OS1 and OS2 safety outputs are enabled (OUT LED on, green). The O4 signalling output is activated at the same time. The safe actuation area is extended in order to allow greater play for the actuator.

The I4 input can be used to unlock the actuator (LOCK LED off). The switch disables the OS1 and OS2 safety outputs and turns off the OUT LED. The O4 signalling output is deactivated at the same time. The safe actuation area returns to the initial values.

When the actuator leaves the actuation limit area, the device turns off the ACT LED and the O3 signalling output.

### Actuation sequence in mode 2

In contrast to the above mode 2 description, the safety outputs OS1 and OS2 enable when the actuator is detected, and disable when the actuator is no longer detectable.

#### Operating states

PWR LED	IN LED	OUT LED	ACT LED	LOCK LED	EDM LED (a)	Device state	Description
○	○	○	○	○	○	OFF	Device switched off.
●	●	●	●	●	●	POWER ON	Internal tests upon activation.
●	○	○	*	*	●	RUN	Safety inputs of the device not active.
●	●	*	*	*	*	RUN	Activation of safety inputs.
●	⚡	○	*	*	*	RUN	Safety inputs incoherence. Recommended action: check for presence and/or wiring of inputs.
●	*	*	●	*	*	RUN	Actuator in safe area. O3 signalling output active.
●	*	*	●	●	○	RUN	Actuator in safe area and locked; O3 and O4 outputs active.
●	●	●	●	●	○	RUN	<b>Mode 1</b> Activation of safety inputs IS1, IS2. Actuator in safe area and locked. O3, O4, OS1 and OS2 outputs active.
●	●	●	●	*	○	RUN	<b>Mode 2</b> Activation of safety inputs IS1, IS2. Actuator in safe area. O3, OS1 and OS2 outputs active.
●	*	⚡	*	*	*	ERROR	Error on safety outputs. Recommended action: check for any short circuits between the outputs, outputs and ground or outputs and power supply, then restart the device.
●	○	○	⚡	○	○	ERROR	Actuator detection error. Check the physical integrity of the device and, in case of failure, please replace the entire device. If undamaged, realign the actuator with the switch and restart the device.
●	○	○	○	○	○	ERROR	Internal error. Recommended action: restart the device. If the failure persists, replace the device.
●	*	○	*	*	●	RUN	EDM signal active (external relay off) <sup>a</sup>
●	●	●	●	●	○	RUN	EDM signal not active (external relay on) <sup>a</sup>
●	○	○	○	○	⚡	ERROR	Error in the EDM <sup>a</sup> function

Legend: ○ = off ● = on ● = flashing ● = alternating colours \* = indifferent (a) Available only in versions NG 2D●●5●●

#### External device monitoring (EDM)

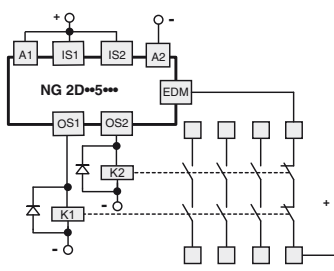

The NG 2D●●5●● version, in addition to maintaining the operating and safety characteristics of the NG series, allows control of **forcibly guided NC contacts of contactors or relays** controlled by the safety outputs of the switch itself. As an alternative to the relays or

contactors you can use Pizzato Elettrica expansion modules CS ME-03.

See page 245. This check is carried out via the EDM input (External Device Monitoring as defined in EN 61496-1) of the switch.

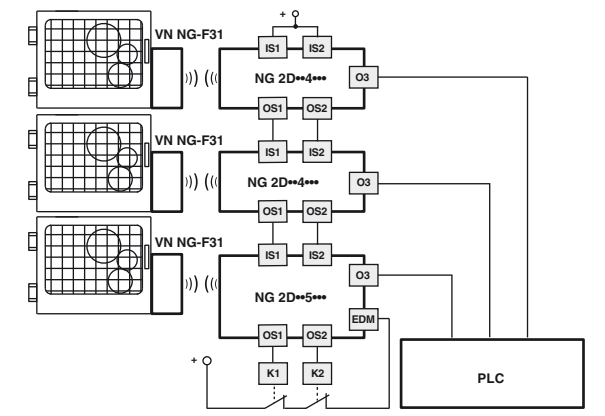

This version, with the IS safety inputs, **can be used at the end of a series of NG switches, up to a maximum number of 32 devices**, while maintaining the maximum PL e safety level and acc. to EN ISO 13849-1 and SIL 3 safety level acc. to EN 62061. This solution allows you to dispense with the safety module connected to the last device in the chain.

### Connection with safety modules

Connections with CS AR-08•••• safety modules

Input configuration with monitored start

2 channels / Category 4 / up to SIL 3 / PL e

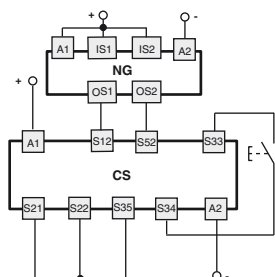

Connections with CS AR-05••••• / CS AR-06••••• safety modules

Input configuration per manual start (CS AR-05•••••)  
or monitored start (CS AR-06•••••)

2 channels / Category 4 / up to SIL 3 / PL e

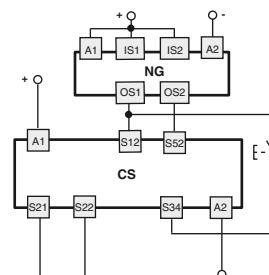

Connections with CS AT-0••••• / CS AT-1••••• safety modules

Input configuration with monitored start

2 channels / Category 4 / up to SIL 3 / PL e

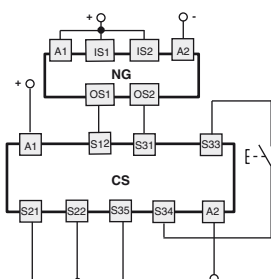

Connections with CS MF•••••, CS MP••••• safety modules

The connections vary according to the program of the module

Category 4 / up to SIL 3 / PL e

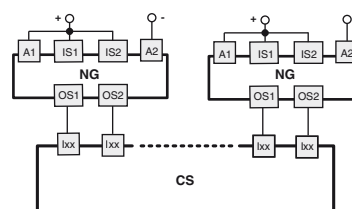

Application example on page 253.

### Pin assignments (version with standard cover NG 2D••••1A)

Internal terminal strip	M23 connector 12-pole	M12 connector, 12-pole	M12 connector, 8-pole stand-alone connection	M12 connector, 8-pole series connection with "Y" connectors	Connection	Connection
A2	3	3	3	3	A2	Supply input 0 V
B2	3	3	3	3	B2	0 V auxiliary supply output
I4	10	10	8	8	I4	Solenoid activation input
O3	5	5	2	/	O3	Signalling output, actuator inserted
O4	9	9	5	5 (c)	O4	Signalling output, actuator inserted and locked (b)
I3	8	8	6	/	I3	Actuator programming input
A1	1	1	1	1	A1	Supply input +24 Vdc
B1	1	1	1	1	B1	Auxiliary supply output +24 Vdc, (I <sub>m</sub> 8 A max.)
IS1	2	2	/	2	IS1	Safety input
IS2	6	6	/	6	IS2	Safety input
I5	11	11	/	/	I5	EDM input (a)
OS1	4	4	4	4	OS1	Safety output
OS2	7	7	7	7	OS2	Safety output

Important: terminals 7, 8, 9, 17, 18 of the internal terminal strip must not be used.

(a) Available in NG 2D••••5•••• version only.

(b) For NG 2D••••6••••, the output signals the fault condition of the device.

(c) Available for 8-pole connector, not available for the end of a chain with Y connectors.

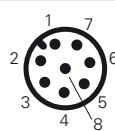
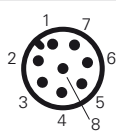
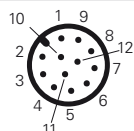
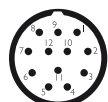
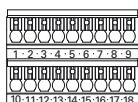





### Dimensional drawings

All values in the drawings are in mm

**Switch NG 2D1D••1A**  
Operating principle D, with sealable auxiliary release device, without actuator

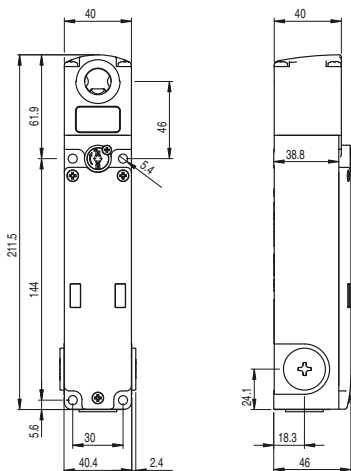

**Switch NG 2D1E••1A**  
Operating principle E, without actuator

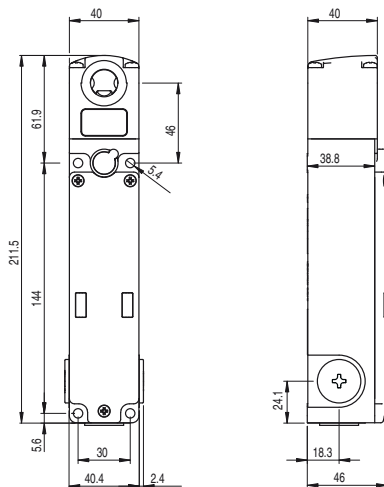

**Switch NG 2D5D••1A**  
Operating principle D, with key release, without actuator

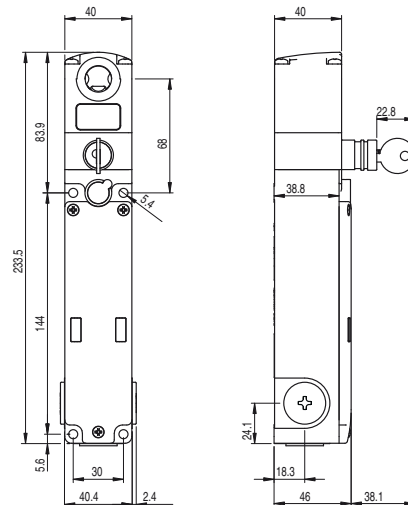

**Switch NG 2D6D••1A**  
Operating principle D, with key release and emergency release button, without actuator

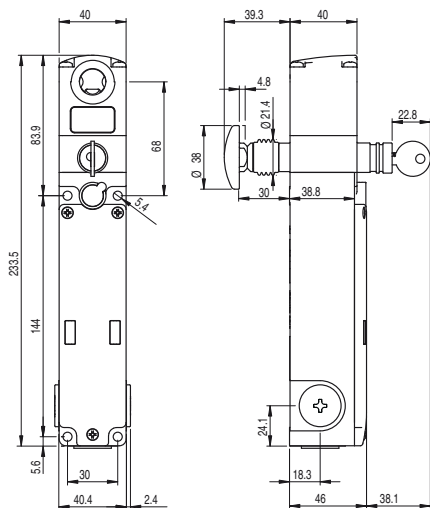

**Switch NG 2D7D••1A**  
Operating principle D, with emergency release button, without actuator

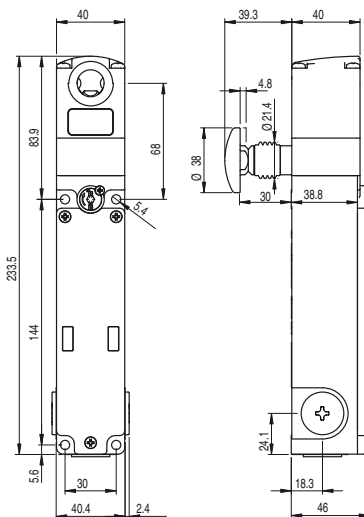

**Switch NG 2D7E••1A**  
Operating principle E, with emergency release button, without actuator

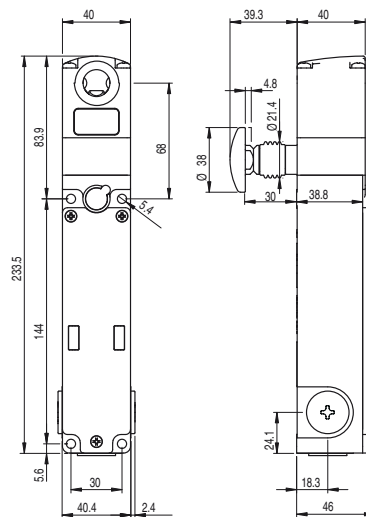

**Actuator VN NG-F3•**

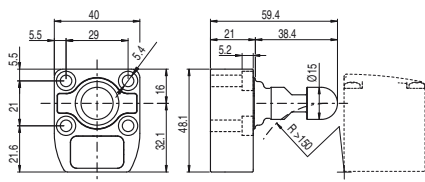

→ The 2D and 3D files are available at [www.pizzato.com](http://www.pizzato.com)

## Switch with integrated field-wireable control devices

## NG 2D••••1C

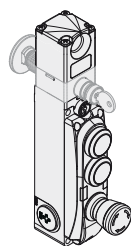

Description	Actuator colour	Terminals
illuminated button, spring-return 1NO+1NC	white	19 21 31 E- 20 22 34
illuminated button, spring-return 1NO+1NC	yellow	23 25 32 E- 24 26 34
emergency button, not illuminated, with rotary release 2NC	red	27 29 E- 28 30

## NG 2D••••1D

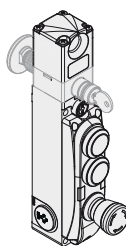

Description	Actuator colour	Terminals
illuminated button, spring-return 1NO+1NC	white	19 21 31 E- 20 22 34
button, not illuminated, spring-return 1NO+1NC	black	23 25 E- 24 26
emergency button, not illuminated, with rotary release 2NC	red	27 29 E- 28 30

## NG 2D••••1E

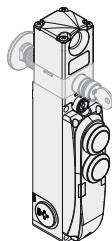

Description	Actuator colour	Terminals
illuminated button, spring-return 1NO+1NC	white	19 21 31 E- 20 22 34
button, not illuminated, spring-return 1NO+1NC	black	23 25 E- 24 26

## NG 2D••••1F

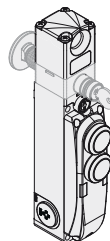

Description	Actuator colour	Terminals
illuminated button, spring-return 1NO+1NC	green	19 21 31 E- 20 22 34
illuminated button, spring-return 1NO+1NC	red	23 25 32 E- 24 26 34

## NG 2D••••1G

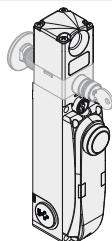

Description	Actuator colour	Terminals
illuminated button, spring-return 1NO+1NC	green	19 21 31 E- 20 22 34

## NG 2D••••1H

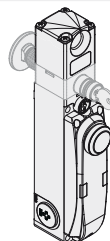

Description	Actuator colour	Terminals
illuminated button, spring-return 1NO+1NC	white	19 21 31 E- 20 22 34

## Terminal assignments (version with integrated control devices)

Terminal no.	Connection	NG 2D••••1C NG 2D••••1D		NG 2D••~1E NG 2D•~1F		NG 2D•~1G NG 2D•~1H	
		1	2	1	2	1	2
1	A2 Supply input 0 V	1	1	1	1	1	1
2	B2 0 V auxiliary supply output	2	2	2	2	2	2
3	I4 Solenoid activation input	3	3	3	3	3	3
4	O3 Signalling output, actuator inserted	4	4	4	4	4	4
5	O4 Signalling output, actuator inserted and locked (b)	5	5	5	5	5	5
6	I3 Actuator programming input	6	6	6	6	6	6
10	A1 Supply input +24 Vdc	10	10	10	10	10	10
11	B1 Auxiliary supply output +24 Vdc, (I <sub>th</sub> 8 A max.)	11	11	11	11	11	11
12	IS1 Safety input	12	12	12	12	12	12
13	IS2 Safety input	13	13	13	13	13	13
14	I5 EDM input (a)	14	14	14	14	14	14
15	OS1 Safety output	15	15	15	15	15	15
16	OS2 Safety output	16	16	16	16	16	16

Important: terminals 7, 8, 9, 17, 18 of the internal terminal strip must not be used.

(a) Available in NG 2D••~5••• version only.  
 (b) For NG 2D••~6•••: the output signals the fault condition of the device.

Terminal no.	Connection	Device
19	Contact 1	Device 1
20	Contact 2	
21	Contact 1	Device 2
22	Contact 2	
23	Contact 1	Device 3
24	Contact 2	
25	Contact 1	Device 3
26	Contact 2	
27	Contact 1	Device 3
28	Contact 2	
29	Contact 1	Device 3
30	Contact 2	
31	Supply input +24 Vdc / LED device 1	
32	Supply input +24 Vdc / LED device 2	
33	Supply input +24 Vdc / LED device 3	
34	Supply input 0 V / LED	



### Switch with integrated control devices and M23 connector, 19-pole

NG 2D••••1C-K603

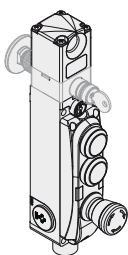

Description	Actuator colour	Pin no.
illuminated button, spring-return 1NO	white	17 18 E-   ⊗ LED
illuminated button, spring-return 1NO	yellow	6 19 E-   ⊗ LED
emergency button, not illuminated, with rotary release 2NC	red	6 19 10 13 11 14

NG 2D••••1D-K603

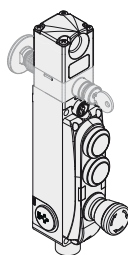

Description	Actuator colour	Pin no.
illuminated button, spring-return 1NO	white	17 18 E-   ⊗ LED
button, not illuminated, spring-return 1NO	black	6 19 E-
emergency button, not illuminated, with rotary release 2NC	red	6 19 10 13 11 14

NG 2D••~1E-K602

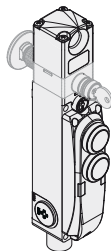

Description	Actuator colour	Pin no.
illuminated button, spring-return 1NO	white	17 18 E-   ⊗ LED
button, not illuminated, spring-return 1NO	black	6 19 E-

NG 2D••~1F-K602

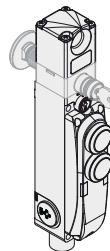

Description	Actuator colour	Pin no.
illuminated button, spring-return 1NO	green	17 18 E-   ⊗ LED
illuminated button, spring-return 1NO	red	6 19 E-   ⊗ LED

NG 2D••~1G-K601

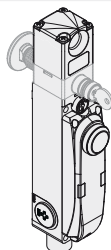

Description	Actuator colour	Pin no.
illuminated button, spring-return 1NO	green	17 18 E-   ⊗ LED

NG 2D••~1H-K601

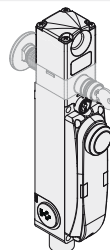

Description	Actuator colour	Pin no.
illuminated button, spring-return 1NO	white	17 18 E-   ⊗ LED

### Terminal assignments (version with integrated control devices)

M23 connector, 19-pole	Connection
19	A2 Supply input 0 V
19	B2 0 V auxiliary supply output
1	I4 Solenoid activation input
8	O3 Signalling output, actuator inserted
9	O4 Signalling output, actuator inserted and locked (b)
7	I3 Actuator programming input
6	A1 Supply input +24 Vdc
6	B1 Auxiliary supply output +24 Vdc, (I <sub>th</sub> 8 A max.)
2	IS1 Safety input
3	IS2 Safety input
12	I5 EDM input (a)
4	OS1 Safety output
5	OS2 Safety output

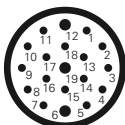

Important: terminals 7, 8, 9, 17, 18 of the internal terminal strip must not be used.  
 (a) Available in NG 2D••~5••• version only  
 (b) For NG 2D••~6•••: the output signals the fault condition of the device.

17	Contact 1	Device 1
6	Contact 2	
/	/	Device 2
15	Contact 1	
6	Contact 2	
/	/	Device 3
10	Contact 1	
11	Contact 2	
13	Contact 1	Device 3
14	Contact 2	
18	Supply input +24 Vdc / LED device 1	
16	Supply input +24 Vdc / LED device 2	
/	Supply input +24 Vdc / LED device 3	
19	Supply input 0 V / LED	

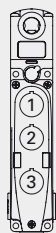

NG 2D••~1C-K603  
NG 2D••~1D-K603

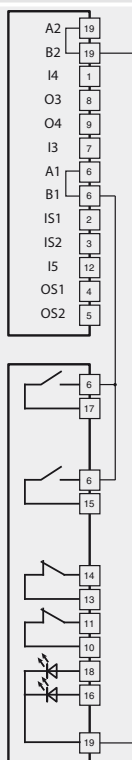

NG 2D••~1E-K602  
NG 2D••~1F-K602

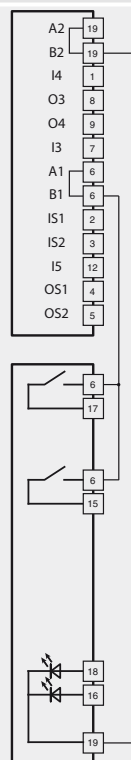

NG 2D••~1G-K601  
NG 2D••~1H-K601

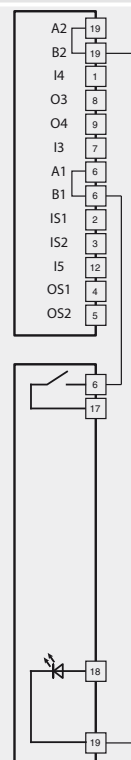

Female connectors see page 299

## Dimensional drawings values in the drawings are in mm

NG 2D ..... switch with integrated control devices

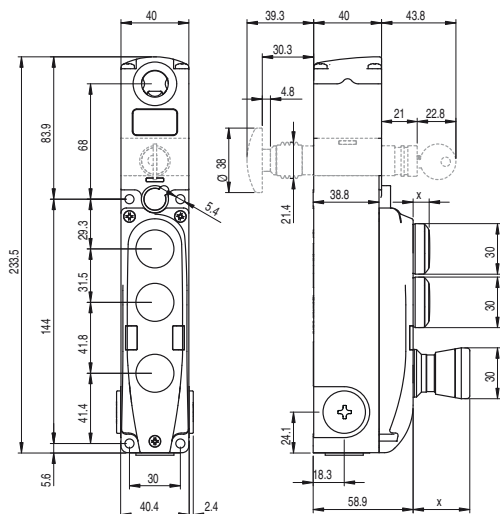

## Available integrated devices

	Description	Colours	Article	Combinable with contacts	Installation height (x) mm
	Illuminated button, spring-return	○ White ● Red ● Green ● Yellow ● Blue	VN NG-AC26005 VN NG-AC26001 VN NG-AC26003 VN NG-AC26002 VN NG-AC26004	1NO 2NO 1NO+1NC	10
	Button, not illuminated, spring-return	● Black	VN NG-AC26007	1NO 2NO 1NO+1NC	10
	Indicator light	○ White ● Red ● Green	VN NG-AC26064 VN NG-AC26060 VN NG-AC26062	/	9.7
	Emergency button acc. to EN ISO 13850			2NC	33.4
	Rotary release Push-pull release	● Red ● Red	VN NG-AC26052 VN NG-AC26055		
	Emergency release button, illuminated, acc. to EN ISO 13850			2NC	33.4
	Rotary release Push-pull release	● Red ● Red	VN NG-AC26051 VN NG-AC26054		
	Illuminated selector switch with handle, with transparent lens for LED	● Black ● Black	VN NG-AC26033 VN NG-AC26034	1NO 2NO 1NO+1NC	23.8
	Key selector switch, 2 positions	● Black ● Black	VN NG-AC26040 VN NG-AC26043	1NO 2NO 1NO+1NC	without key 21~ with key 46~
	Closing cap	● Black	VN NG-AC26090	/	4
	Fixing key	● Black	VN NG-AC26080	/	/

Legend: Maintained Spring-return Key extraction position

Other devices and contacts on request.

Please contact our technical office for the complete list of available products.

## Technical data of the integrated control devices

### General data

Protection degree:	IP65 acc. to EN 60529	
Mechanical endurance:	300,000 operating cycles	
Spring-return button:	1 million operating cycles	
Emergency button:	50,000 operating cycles	
Selector switch:	300,000 operating cycles	
Key selector switch:	50,000 operating cycles	
	30,000 operating cycles including removal of the key	

### Actuating force:

Spring-return button:	4 N min	100 N max.
Emergency button:	20 N min	100 N max.
Selector switch:	0.1 Nm min	1.5 Nm max.
Key selector switch:	0.1 Nm min	1.3 Nm max.

### Contact blocks of the control devices

Material of the contacts:	silver contacts
Contact type:	Self-cleaning contacts with double interruption

### Electrical data:

Thermal current $I_{th}$ :	1 A
Rated insulation voltage $U_i$ :	32 Vac/dc
Rated impulse withstand voltage $U_{imp}$ :	1.5 kV
LED supply voltage:	24 Vdc $\pm$ 15%
LED supply current:	10 mA per LED

### Utilization category of the contact block:

Direct current: DC13
$U_e$ (V) 24
$I_e$ (A) 0.55

### In compliance with standards:

IEC 60947-5-1, IEC 60947-5-5, EN ISO 13850

### ⚠ Installation for safety applications:

Always connect the safety circuit to the **NC contacts** (normally closed contacts) as stated in standard EN 60947-5-1.



### Extensions for release button

Article	Description	Drawing
VN NG-LP30	Metal extension for release button. For max. wall thickness of 30 mm	
VN NG-LP40	Metal extension for release button. For max. wall thickness of 40 mm	
VN NG-LP50	Metal extension for release button. For max. wall thickness of 50 mm	
VN NG-LP60	Metal extension for release button. For max. wall thickness of 60 mm	
VN NG-ERB	Red metal release button	

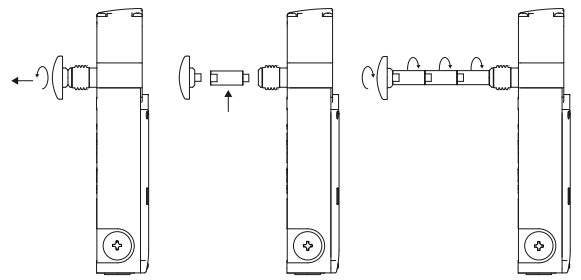

- Metal extensions can be combined with one another to achieve the desired length.
- Do not exceed an overall length of 500 mm between the release button and the switch.
- Use medium-strength thread locker to secure the extensions.

### Compatibility with P-KUBE 2 safety handles

Anywhere it is necessary to monitor access to dangerous areas of machines or systems, the P-KUBE 2 safety handles can be used on doors or guards.

Together with the NG series RFID safety switches with guard locking, these door handles form an integrated locking system for guards that enables access control to dangerous areas. This combination allows a robust system to be created completely out of metal which is compact and configurable. It contains an RFID safety switch with centring pin for the door and optional emergency release button, an adjustable handle with LOCK OUT device and command devices.

The same article can be used on hinged doors with left and right stop as well as with sliding doors.

Article	Description	Article	Description	Article	Description
AP G1A-111P	Safety door handle with LOCK OUT device, with 3 plates with multiple fastening options	AP G1A-011P	Safety door handle with LOCK OUT device, with 2 plates with multiple fastening options	AP G1Z-200P	Safety door handle with LOCK OUT device, with 1 plate

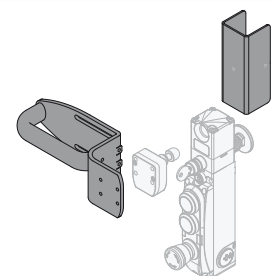
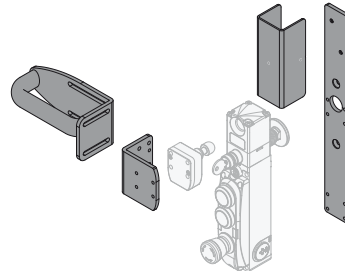
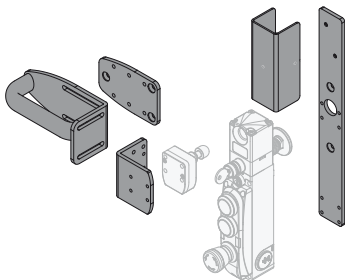

### Adhesive labels for emergency release button



Polycarbonate yellow adhesive, rectangular, 300x32 mm, red inscription. It has to be fixed on the internal part of the jamb and helps finding the emergency release button.

Article	Description
VF AP-A1AGR01	PREMERE PER USCIRE
VF AP-A1AGR02	PUSH TO EXIT
VF AP-A1AGR04	ZUM ÖFFNEN DRÜCKEN
VF AP-A1AGR05	POUSSER POUR SORTIR
VF AP-A1AGR06	PULSAR PARA SALIR
VF AP-A1AGR07	НАЖАТЬ ДЛЯ ВЫХОДА
VF AP-A1AGR08	NACISNAĆ ABY WYJŚĆ
VF AP-A1AGR09	PRESIONAR PARA SAIR

### Accessories

Article	Description
VF KLB300	Set of two locking keys

Extra copy of the locking keys to be purchased if further keys are needed (standard supply: 2 units).  
The keys of all switches have the same code. Other codes on request.



### Series connection

To simplify series connections of the devices, various M12 connectors are available that allow complete wiring.

This solution significantly reduces installation times while at the same time maintaining the maximum safety levels PL e and SIL 3.

For further information see page 304.

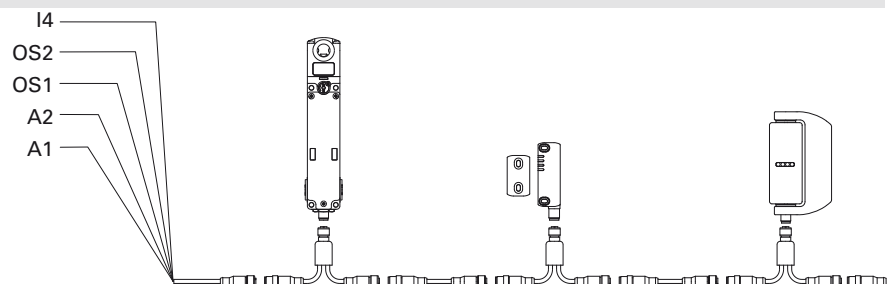

Items with code on **green** background are stock items